

USER MANUAL

Airdata Indicator 2

Version 1.0



1	Important notices	3
1.1	Limited warranty	3
2	Packing lists	4
3	ADI2 basics	5
3.1	The ADI2 at a glance	5
3.1.1	ADI features	5
3.1.2	Interfaces	5
3.1.3	Technical data	6
4	Wiring and static ports	8
4.1	Pinout	8
4.2	Pressure ports connections	8
5	Installation	9
5.1	Parts effected	9
5.2	Parts removed	9
5.3	Parts installed	10
5.4	Prerequisites:	10
5.5	Installation Process	10
5.6	Post Installation Configuration, Checkout, and Documentation	12
5.7	Cut-out	12
6	System description	13
6.1	Rotary push knob	13
6.2	Switching on the unit	13
6.3	User input	13
6.3.1	Navigating menu and dialogs	14
6.3.2	Radio on/off button	14
6.3.3	Selection control	14
6.3.4	Spin control	15
6.3.5	Slider control	15
6.3.6	Text controls	15
7	Operating modes	16
7.1	Main screen	16
7.2	QNH changing	16
7.3	Battery indication	17
7.4	Setup mode	17
7.4.1	Display	18
7.4.2	Layout	18
7.4.3	Installation menu	19
7.4.3.1	Units	19
7.4.3.2	Speeds	20
7.4.3.3	Wi-Fi	21
7.4.3.4	Scale origin	21
7.4.3.5	TAS method	22
7.4.3.6	Vario filter	22
7.4.4	Temperature offset	22
7.4.5	Password	22
7.5	About	23
8	Instructions for continued Airworthiness (ICA)	24
8.1	Occurrence reporting	24
9	Revision history	25

1 Important notices

The Airdata indicator 2 (ADI2) is not ETSO approved device. However it can be installed in airplane with STC (10088573) to substitute airspeed indicator and/or altimeter mandated by the flight- and/or maintenance manual of the airplane.

It is ultimately the pilot's responsibility to ensure that the aircraft is being flown in accordance with the manufacturer's aircraft flight manual. Aircraft operation is limited to VFR/day operation. The operation of the aircraft is not permitted, if either the ADI2 or the backup instrument is not operative.

The ADI2 must be installed in accordance with this manual by a competent and qualified personnel using standard maintenance procedures.

Information in this document is subject to change without notice. LXNAV reserves the right to change or improve their products and to make changes in the content of this material without obligation to notify any person or organization of such changes or improvements.



A Yellow triangle is shown for parts of the manual which should be read carefully and are important for operating the Airdata indicator.



Notes with a red triangle describe procedures that are critical and may result in loss of data or any other critical situation.



A bulb icon is shown when a useful hint is provided to the reader.

1.1 Limited warranty

This ADI2 product is warranted to be free from defects in materials or workmanship for two years from the date of purchase. Within this period, LXNAV will, at its sole option, repair or replace any components that fail in normal use. Such repairs or replacement will be made at no charge to the customer for parts and labor, the customer shall be responsible for any transportation cost. This warranty does not cover failures due to abuse, misuse, accident, or unauthorized alterations or repairs.

THE WARRANTIES AND REMEDIES CONTAINED HEREIN ARE EXCLUSIVE AND IN LIEU OF ALL OTHER WARRANTIES EXPRESSED OR IMPLIED OR STATUTORY, INCLUDING ANY LIABILITY ARISING UNDER ANY WARRANTY OF MERCHANTABILITY OR FITNESS FOR A PARTICULAR PURPOSE, STATUTORY OR OTHERWISE. THIS WARRANTY GIVES YOU SPECIFIC LEGAL RIGHTS, WHICH MAY VARY FROM STATE TO STATE.

IN NO EVENT SHALL LXNAV BE LIABLE FOR ANY INCIDENTAL, SPECIAL, INDIRECT OR CONSEQUENTIAL DAMAGES, WHETHER RESULTING FROM THE USE, MISUSE, OR INABILITY TO USE THIS PRODUCT OR FROM DEFECTS IN THE PRODUCT. Some states do not allow the exclusion of incidental or consequential damages, so the above limitations may not apply to you. LXNAV retains the exclusive right to repair or replace the unit or software, or to offer a full refund of the purchase price, at its sole discretion. SUCH REMEDY SHALL BE YOUR SOLE AND EXCLUSIVE REMEDY FOR ANY BREACH OF WARRANTY.

To obtain warranty service, contact your local LXNAV dealer or contact LXNAV directly.

2 Packing lists

- Airdata indicator (ADI2)
- Power supply cable
- OAT probe
- Declaration of conformity

3 ADI2 basics

3.1 The ADI2 at a glance

The Airdata indicator 2 or ADI2 is standalone unit designed to indicate airspeed, altitude and outside air temperature. It is capable of measuring the pitot- and static pressure digitally using calibrated sensors.

The unit has standard dimensions that will fit into the instrument panel with an opening of 57 mm diameter or 80 mm diameter.

The values are displayed on a sunlight readable display. The display can be configured using a password protected installation menu. It shall be configured showing the applicable colored ARCs as per AFM on the display. Additional numerical values can be configured as per convenience. One rotary and push knob is used to adjust values QNH value and input other settings, while on ground

3.1.1 ADI features

- Airspeed sensor: 12 bit, 0 to 75 hPa, 370 km/h with resolution less than 0.1 km/h (optional)
- Barometric sensor: 24 bit, 10 hPa - 1200 hPa, 10 cm resolution.
- An extremely bright 2.1" round color display readable in all sunlight conditions with the ability to adjust the backlight.
- Rotary push knob for operation
- 57mm (2.25") or 80mm (3.15") version

3.1.2 Interfaces

- Wi-Fi – just to be used by manufacturer
- CAN for future use

3.1.3 Technical data

Ranges:

- IAS range: 370km/h (200kts)
- Altitude range: 9000m (29500ft)

ADI57

- Power input 8-32V DC
- Consumption 90-140mA@12V
- Dimming input 0-24V (Not in use!)
- Weight 195g
- Dimensions: 57 mm (2.25") cut-out
- 62x62x40mm

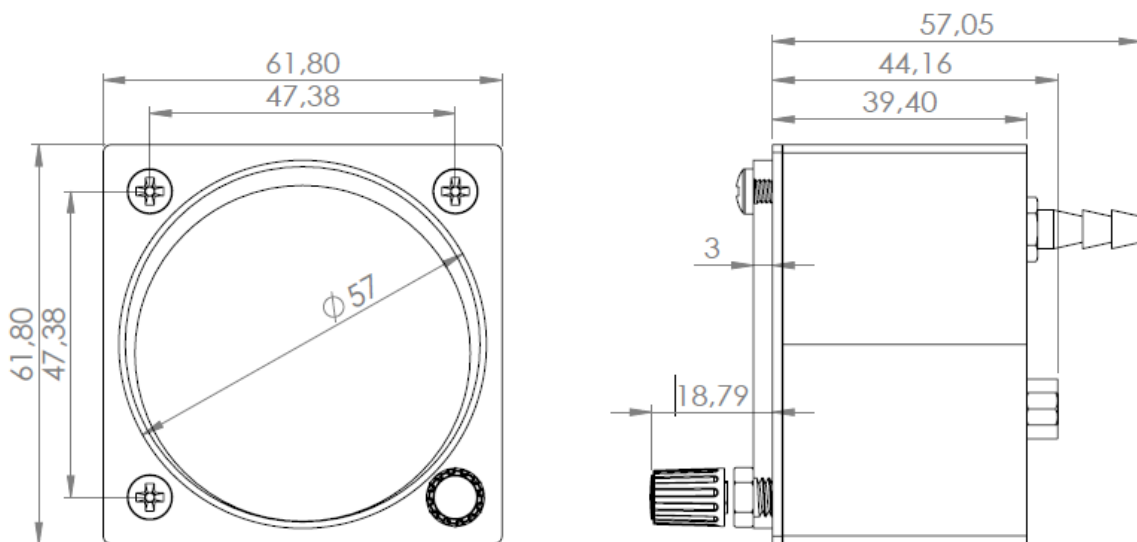

ADI80

- Power input 8-32V DC
- Consumption 90-140mA@12V
- Dimming input 0-24V (Not in use!)
- Weight 315g
- Dimensions: 80 mm (3,15") cut-out
- 80x81x45mm

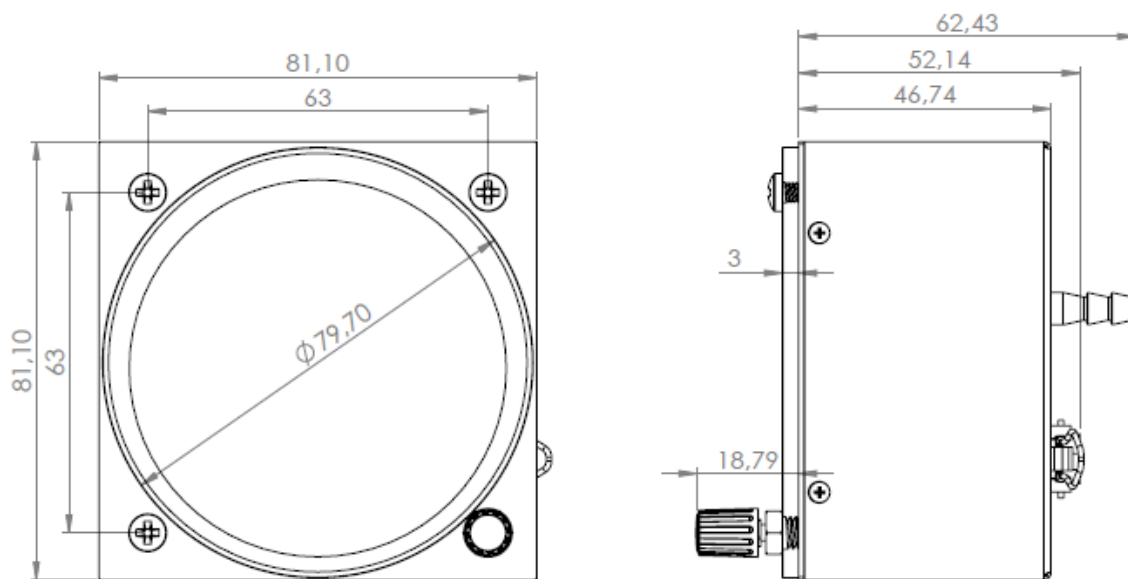

Recommended fuse for ADI2 is **1A**

4 Wiring and static ports

4.1 Pinout

Pin Number	Description
1	Not in use
2	CAN_L not used
3	Ground
4	N/C
5	Shield/Ground
6	N/C
7	CAN_H not used
8	OAT
9	Power supply

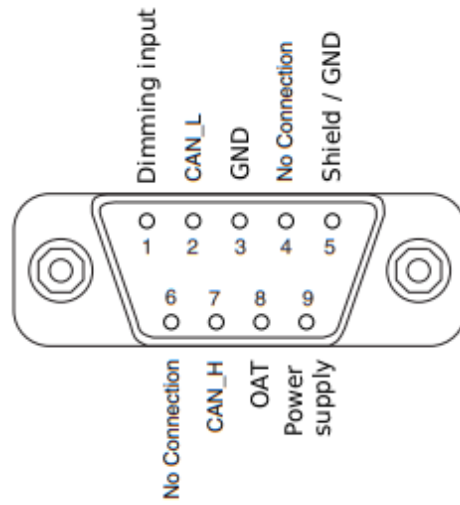

4.2 Pressure ports connections

Two ports are on the back of Airdata indicator P_{static} static pressure port and P_{total} pitot or total pressure port.

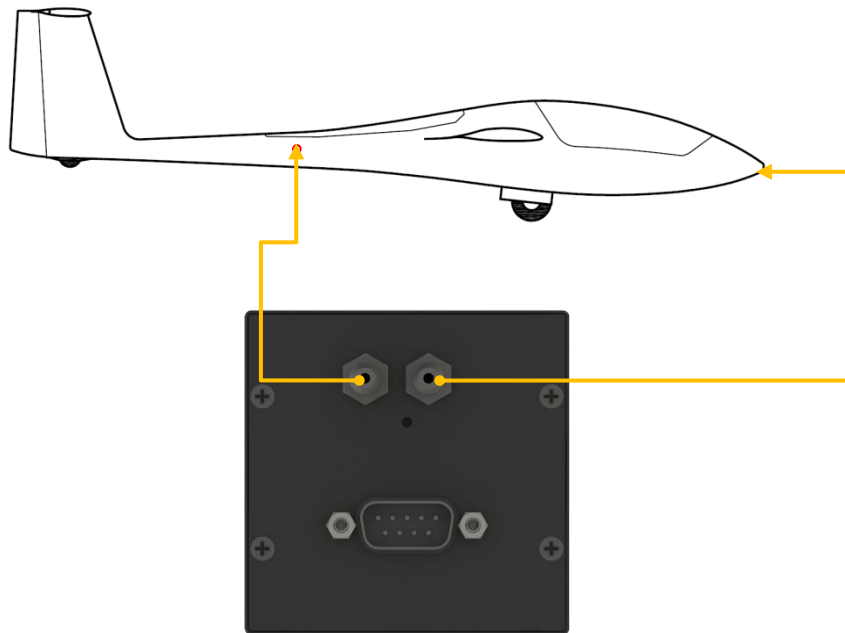

5 Installation

The ADI2 requires a standard 57mm or 80mm cut-out. On the back it is fitted with two pressure ports for total pressure and static pressure.

OAT (outside air temperature) probe that comes with the device must be properly installed to reach outside air. When used to replace an outside air temperature (OAT) thermometer required by the Flight or Maintenance Manual, the probe must be installed in the same location as the sensor of the thermometer being replaced.

More about pinout and pressure ports connections is available in chapter 4: *Wiring and static ports*.

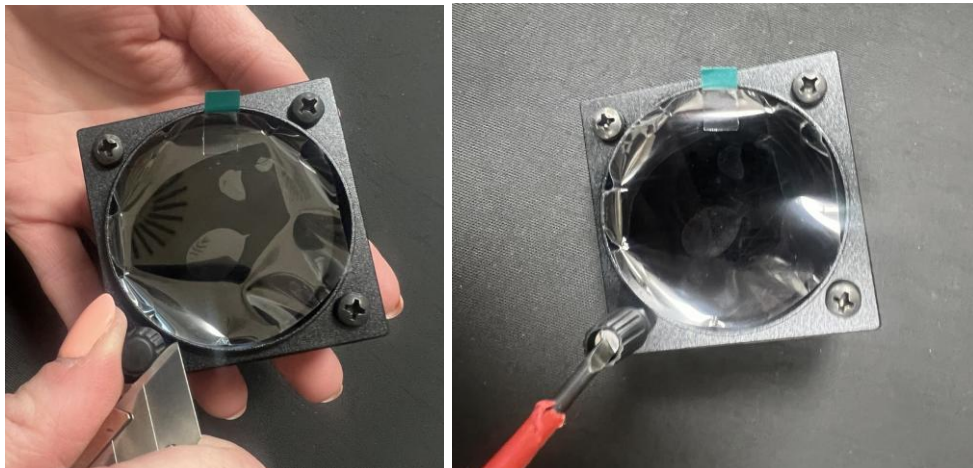
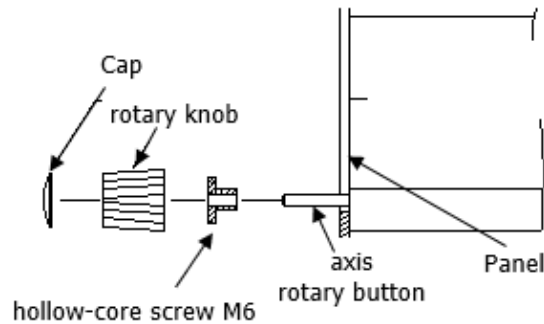

Remove the rotary knob cap with a knife or flat screw driver, then hold knob and unscrew it. Remove the remaining screw and the M6 threaded nut. Install the ADI2 into the panel and screw back all screws, nut and knob. Ensure that between the knob and the panel there is sufficient space so that the button can be pushed.

5.1 Parts effected

5.2 Parts removed

In case you are going to replace existing airspeed and altimeter, you should remove them according to the table below.

Part description	Technical Standard Order	Remark
Airspeed indicator	ETSO-C46a or equivalent	Removal as per operators' discretion
Altimeter	ETSO-C10b or equivalent	Removal as per operators' discretion

5.3 Parts installed

For installation of ADI2 you will need:

Part description	Software release	Remark
ADI2	FW 1.0	Software not field loadable (non FLS)
Installation material	---	Tube, cables and connectors as required
1A circuit breaker	---	Texas Instruments / Klixon 7277 Series Circuit Breaker or similar

5.4 Prerequisites:

ADI2 needs to be ordered or configured to show any airspeed limitation required by the Airplane flight manual (AFM, usually section 2).



Airspeed indicator layout for arcs and markings according to CS 22 can be found in AMC 22.1545 or in Chapter 7.4.3.2 of this manual.

An additional electronic flight display (e.g. electronic variometer, navigation computer or final glide calculator) needs to be installed and configured to be able to show indicated Airspeed (IAS) and barometric altitude simultaneously on one page. To reduce the probability of failure of both systems at the same time, this additional system shall not be an ADI2, as well.



Recommend devices for additional flight display are following: LX90xx or LX80xx series and S-vario series. This list is not complete, installer needs to check each system installed on the aircraft for the suitability

The electrical system must be able to cope with the additional load. This regards to the capacity of the batteries, the cross sections of the wires and the fuses. In powered sailplanes with battery ignition system, the capacity of the batteries and generators must be large enough to meet the simultaneous demands of the engine ignition system and the greatest demands of any other electrical system components that draw from the same source.

The maintenance manual instructions regarding the pneumatic lines and ports must be followed. After work on the pneumatic installation, the system must be checked for tightness. The equipment must securely be attached in the sailplane, must neither endanger the pilot, nor hinder bailing out, nor weaken the structure.

5.5 Installation Process

Installation shall be in instrument panel, consisting with existing cockpit layout. Any limitation from Maintenance instructions applies (e.g. Panel weight). As this instrument is the most important instrument for a (powered) glider, it should be placed in a very visible place, e.g. in the top of the panel.

ADI2 needs to be wired directly to the aircraft master switch ("always on") with a resettable circuit breaker rated 1A (e.g. Texas Instruments / Klixon 7277 Series Circuit Breaker or similar). This circuit breaker must not be connected to any other system required for safe flight, explicitly not connected to the electronic device used as backup system.

No alteration to pitot or static ports of the aircraft shall be made.

OAT probe shall be mounted on the measuring spot foreseen by the Airframe manufacturer.

For general purpose and structural considerations, use FAA Advisory Circular AC43.13-1B+2B.

“INSTALLATION OF BASIC FLIGHT INSTRUMENTS” Standard Change CS-SC401d can be used as approved data, if Maintenance Manual or similar approved data (Technical Notes TN) do not contain sufficient information

5.6 Post Installation Configuration, Checkout, and Documentation

- Check that Airspeed Markings / Arc are in line with basic Airplane flight manual AFM and applicable Type certificate data Sheet (TCDS).
- Check that measuring range of Airspeed indicator is at least 1,05 times Vne
- Check Backup instrument is in working condition and configured to be able to display IAS and Altitude simultaneously
- Perform a Pitot-/Static test in accordance with AC43.13 App for ADI2 and backup instrument
- Perform aircraft weighing according to Flight or Maintenance manual, if needed. Update the AFM and placards accordingly
- Add Flight manual supplement "Electronic Airspeed indicator + Altimeter ADI2" to AFM
- Update Aircraft documentation (e.g. STC/Alteration list, equipment list, weighing report)
- Release aircraft to service according to applicable requirements. Note: This STC is not suitable for the release to service of the aircraft by the pilot-owner

Note to certifying staff: According to Regulation (EU) 2021/699 and 21.A.307 (c):

*(c) Parts and appliances listed in point (b) are eligible for installation in a type-certified product **without being accompanied by an EASA Form 1**, provided that the installer holds a document issued by the person or organization that manufactured the part or appliance, which declares the name of the part or appliance, the part number, and the conformity of the part or appliance with its design data, and which contains the issuance date.*

Therefore ADI2 can be installed and release without being accompanied by an EASA Form 1

5.7 Cut-out

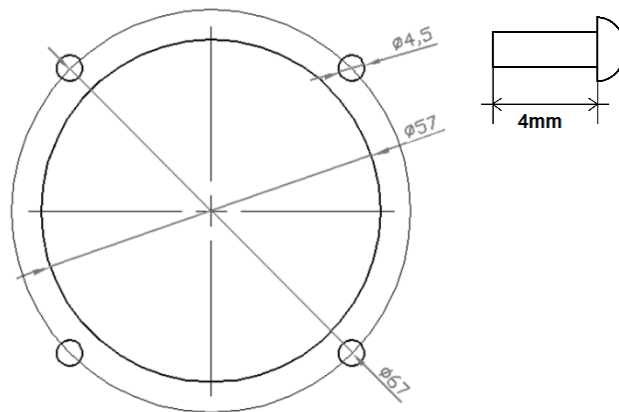

Bottom right hole should be at least 6mm in diameter!

6 System description

6.1 Rotary push knob

ADI2 has one rotary push knob. Knob can be rotated CCW and CW to select QNH, to navigate through menus or to select a value. It also has push functionality and detects short or long presses. A short press means just a click; a long press means pushing the button for more than one second.

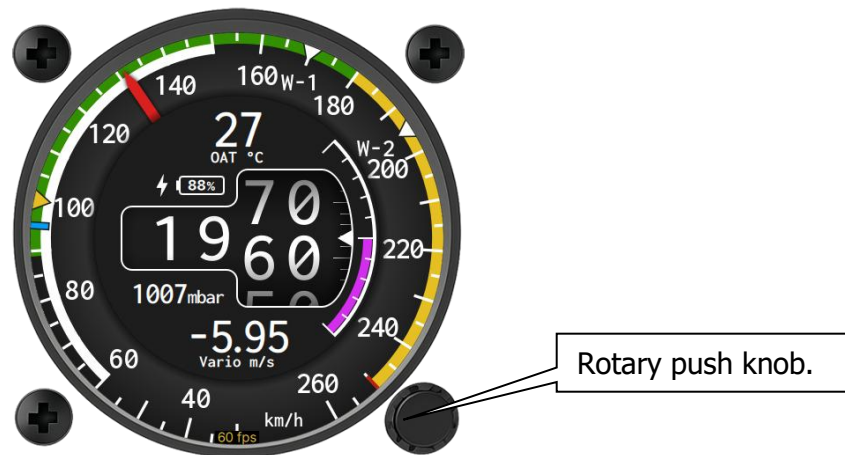

6.2 Switching on the unit

There is no special action required to switch on the unit. When power is applied to the device, it will switch on and will be ready for immediate use.

6.3 User input

The user interface consists also of dialogues which have various input controls. They are designed to make the input of names, parameters, etc., as easy as possible. Input controls can be summarized as:

- Radio on/off button,
- Selection control,
- Spin control,
- Slider control,
- Text inputs

6.3.1 Navigating menu and dialogs

Once in a menu or dialog you can select an item rotating knob in both directions. Once on desired item. Press knob to enter submenu, edit mode or toggle selection.

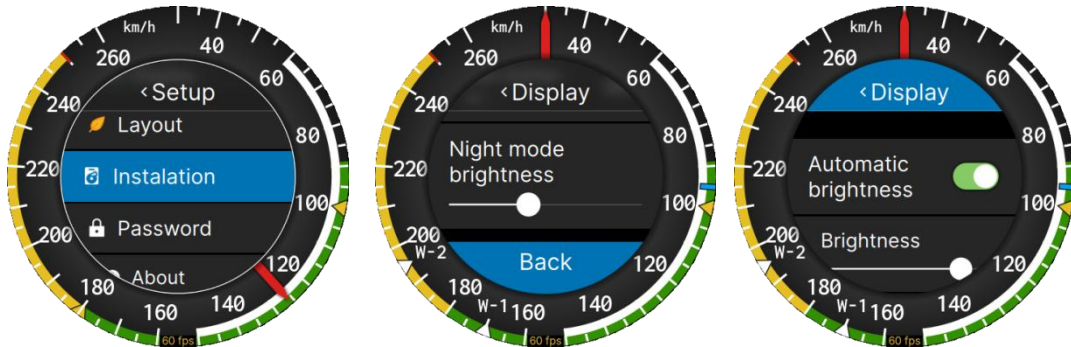

Uppermost selection is dialog name and bottom selection is back. Select this item to go back to previous menu or long press the knob to exit.

6.3.2 Radio on/off button

A radio button enables or disables an option. Press knob to toggle selected option. If an option is enabled radio button will move to the right and background will be colored green.



6.3.3 Selection control

Selection control is used to select a value from a list of predefined values. Press knob button to see all the options. Currently selected value will have a checkmark next to it. You can select an option with rotating the rotary knob. Press knob to confirm selection or select Back to return without changes.

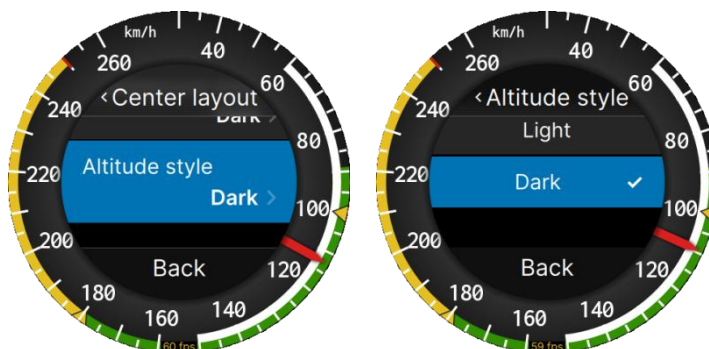

6.3.4 Spin control

Spin control is used to select a numerical value. Press knob to enter edit mode. Currently selected value will be highlighted in blue. Use rotary knob to increase or decrease value. Confirm selection with short press on knob. Long press knob to cancel selection and exit without changes.

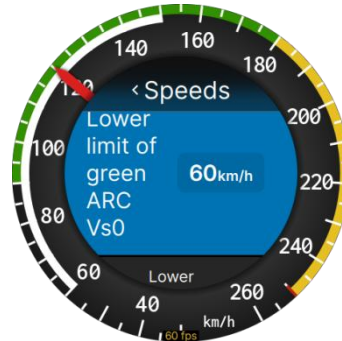

6.3.5 Slider control

Some values, such as volume and brightness, are displayed as a slider.



Press knob to enter edit mode. Slider background colour will change. Use rotary knob to increase or decrease value. Confirm selection with short press on knob. Long press knob to cancel selection and exit without changes.

6.3.6 Text controls

When entering a text. A list with all the options will be shown around the screen. Select a letter or any other option to enter required text. Press Abc symbol to toggle between entering letters, digits and/or symbols.

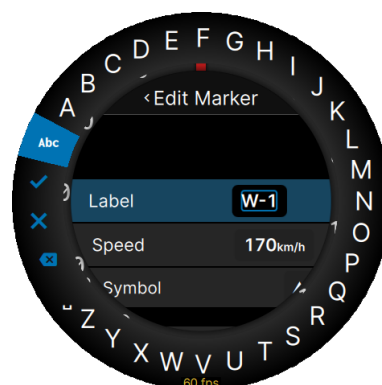

Press and rotate knob to move between the input letters. Confirm selection with checkmark symbol and cancel changes with X symbol.

7 Operating modes

The ADI2 has only one main screen which indicates airspeed, altitude and QNH setting. When rotating the rotary knob QNH is adjusted. Long press on the rotary knob will open the menu, which has timeout and will be closed after 3 seconds.

7.1 Main screen

Primary function of ADI is to display indicated airspeed and altitude. Indicated airspeed is displayed with needle on a customizable dial. See chapter 7.4.3.2 how to customize speeds markings on the dial.

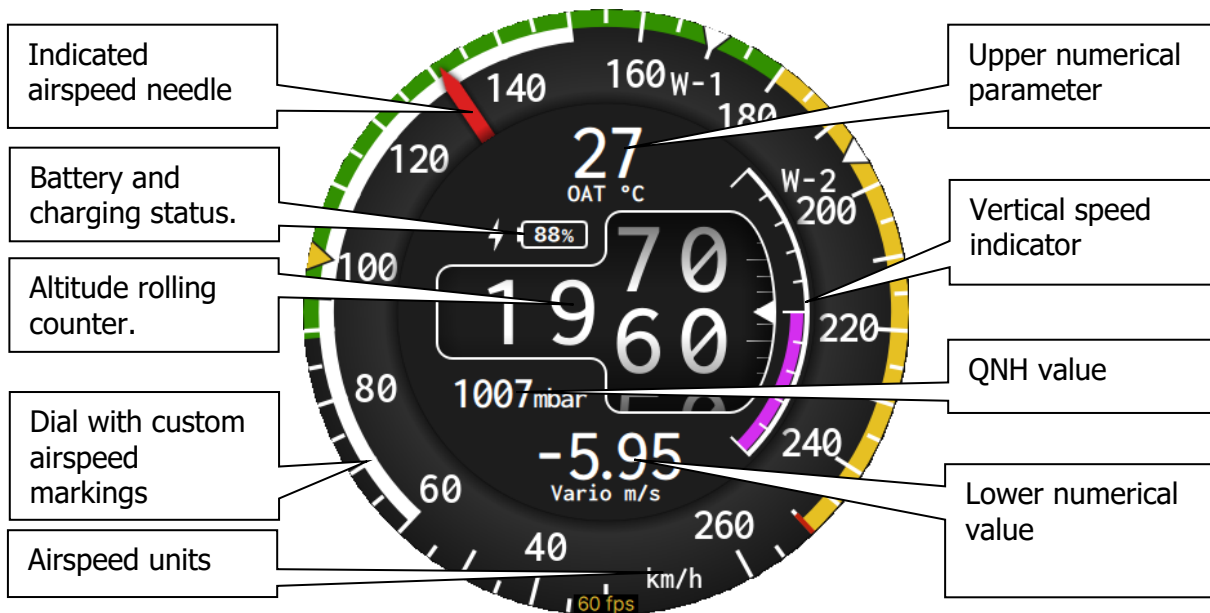

In the middle of screen altitude is displayed as rolling odometer. On the right side vertical speed is drawn as a magenta bar. Additionally, two numerical values can be show. See chapter 7.4.1 how to customize main screen.

7.2 QNH changing

If you rotate rotary knob, QNH value will be highlighted and blue ring will be drawn around altitude indication. Rotate knob to the right to increase QNH and left to decrease QNH. Changes are going to be seen immediately.



Highlight area will disappear automatically after 10 seconds of inactivity.

7.3 Battery indication

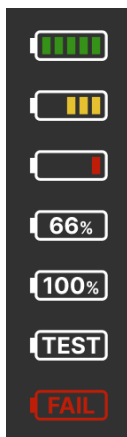

Above the altitude display internal battery status is displayed. On power-up automatic test of the battery is performed and message TEST is shown inside the battery. If battery is not ok and requires a service, message FAIL will be shown and it will be colored red. Please contact us for service. If battery is charging, a charging symbol will be shown next to battery symbol and inside the battery percentage of charge level will be shown. During operation on battery indicator will change to green, yellow or red. A message to the use will be displayed when changing status of the battery, how much time remains.



If external power is lost, the unit will continue operating on the internal battery only while the aircraft is airborne, i.e. when valid airspeed is detected. If no airspeed is present, the unit will shut down immediately.

7.4 Setup mode

Long press the knob to enter setup mode. Setup is used to configure your ADI2.

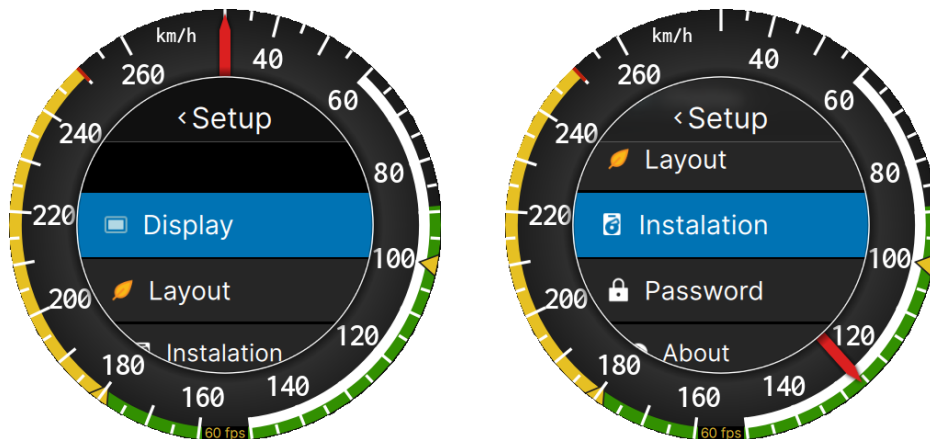

A setup menu with following options will be displayed:

- **Display** – use this menu to set brightness of the screen
- **Layout** – Customize numerical parameters and set theme colors
- **Installation** used by authorized personal to do initial setup of speed markings, units
- **Password** – change vertical speed filter and total energy compensation, if needed.
- **About** – shows version info and

7.4.1 Display

Use this menu to set brightness of the screen



Brightness sets current screen brightness. If automatic brightness is enabled then this control will show current brightness.

If the **Automatic Brightness** box is checked the brightness will be automatically adjusted between the minimum and maximum values.

Get Brighter In specifies in which time period the brightness can reach the required brightness.

Get Darker In specifies in which time period the brightness can reach the required lower brightness.

Night Mode Darkness is used in night mode, which is not implemented yet.

7.4.2 Layout

In layout menu user can customize the color of the dials and backgrounds and additional numerical fields



7.4.3 Installation menu



Installation menu is password protected with unique password for each device. Installation menu is meant to be used by a skilled and authorized personal to enter speed arcs and markings.



Initial access to the installation menu is granted without requiring a password. For all subsequent access attempts, the user must enter the password. The password is provided with the unit and may only be used by authorized personnel to access the menu and modify settings.

Select Installation menu item and enter the password provided.



Once a correct password is entered a menu will open with following options

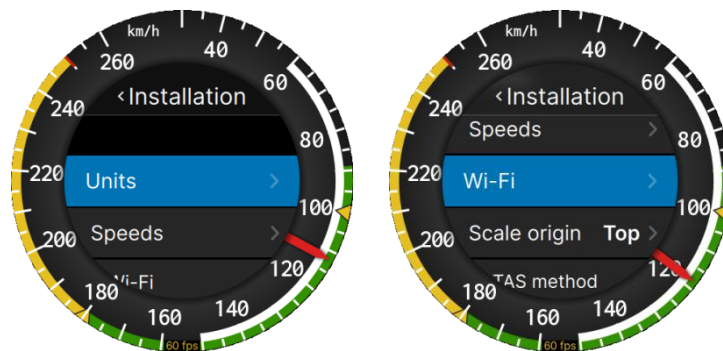

Units is used to define in which system of measure ADI2 is operating

Speeds menu item is used to define speed arcs and markings according to the flight manual

Wi-Fi only used by Manufacturer

Scale Origin defines where indication of zero is on the dial.

TAS method defines how TAS is calculated.

Vario filter is used for sensitivity of the variometer indication

Temperature offset If required, OAT offset can be compensated

7.4.3.1 Units

In this menu you can define system of measure for all the data. Select from predefined sets or change each unit separately.



7.4.3.2 Speeds

In this menu user can define speed arcs and markings according to CS 22 as in AMC 22.1545. Please refer to airplane flight manual (usually Section 2) for speeds. Please refer to Airplane Flight Manual (usually Section 2) for correct Arcs. The following image is for illustrative purposes only, a Scale with more then 360° can not be displayed by the ADI² (as the area in the middle is required for the Altimeter)

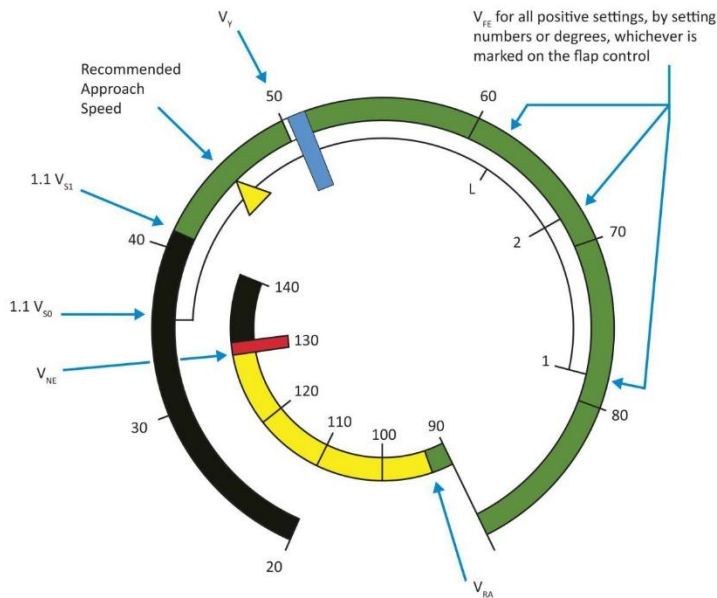

Following speeds shall be entered:

Menu	Description	Remark
Lower limit of white Arc	1,1 times stall speed in landing configuration (V_{S0})	Leave blank, if Aircraft is not equipped with (trailing edge) flap
Lower limit of green arc	1,1 times stall speed in defined flap setting (usually „0“) (V_{S1})	
Yellow Triangle	Recommended approach speed	
Blue Line	Best rate of climb (powered flight) (V_Y)	Leave blank in a glider
Upper limit of white Arc	Maximum Flap Extended Speed (V_{FE})	Leave blank, if Aircraft is not equipped with (trailing edge) flap
Limit between green + yellow Arcs	Rough Air Speed (V_{RA})	
Red radial Line	Never exceed speed (V_{NE})	

Rotate rotary button to select a speed, press it and enter the value from aircraft flight manual.

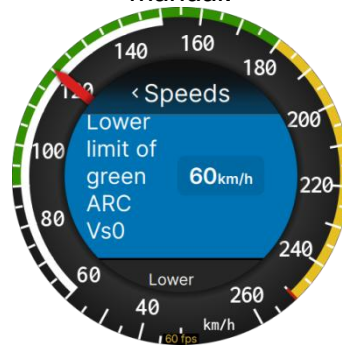

Additional markings can be entered for example different maximum flap speeds for various flap settings. Press Add button to add new markings. Enter name and select symbol type.

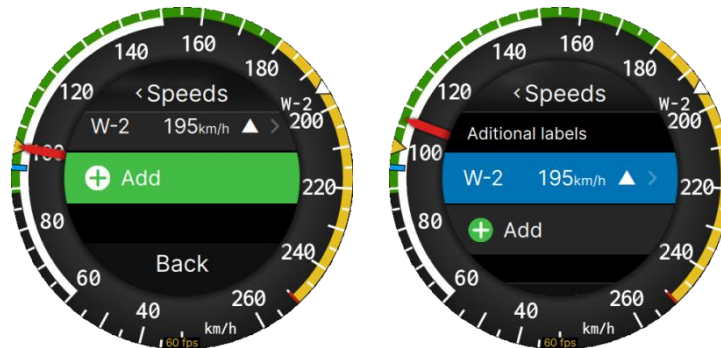

7.4.3.3 Wi-Fi

This menu is designed only to be used by service or manufacturer.

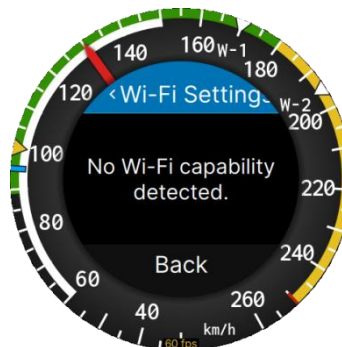

Not to be used by user.

7.4.3.4 Scale origin

Airspace scale origin can be either at the top or at the bottom of the dial. Use this menu to define its position.

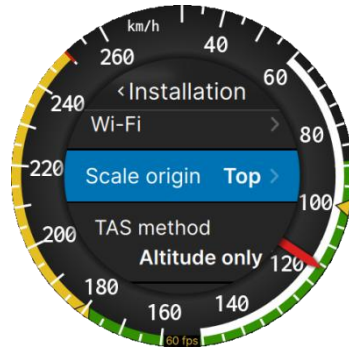

7.4.3.5 TAS method

You can select three methods how true airspeed is calculated. **Altitude only** method is using standard temperature profile with altitude and shall be used only in case OAT probe is not mounted or not working properly, **Altitude and OAT** is method which takes into account density change due to altitude change and temperature change. **Altitude, OAT and Compressibility** is method which takes into account also compressibility of the air and shall be used for faster aircrafts.

7.4.3.6 Vario filter

Vario filter value defines response of the vertical speed indication. Higher value of filter will cause more slow and more filtered response of vertical speed indication.



The range of the vertical speed indicator scale depends on what unit is set in the **Setup-Units-Vertical speed** menu. You can choose between **fpm**, **m/s** or **kts**.

7.4.4 Temperature offset

A temperature offset can be defined here. Temperature offset is same for the whole temperature range. Temperature offset should be set on the ground. If temperature indication is the air is not ok, you should consider relocating OAT probe.

7.4.5 Password

This menu is designed only to be used by service or manufacturer.

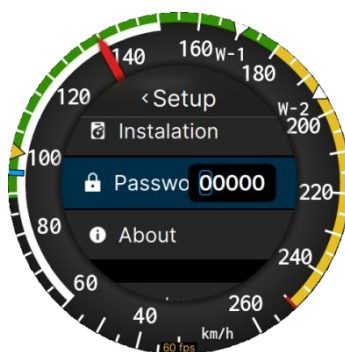

Not to be used by user.

16250 - Show debug info

40000 – Set airspeed threshold (this is threshold, at which ADI switches from ground to airborne mode)

7.5 About



8 Instructions for continued Airworthiness (ICA)

At every airworthiness review following items should be checked:

1. Check the ADI² is showing the applicable colored ARCs and display markings as per basic AFM and TCDS.
2. Check Backup instrument is in working condition and configured to be able to display IAS and Altitude simultaneously.
3. It is recommended to perform a Pitot-/Static test in accordance with FAR 43 App E every 12 month for ADI2 and backup instrument. Airspeed indicator readings during this test shall be within the limits of ETSO-C46a from 24th of October 2003, as shown in the table below.

Speed (IAS)			Pitot pressure		Tolerance		
knots	mph	km/h	inHg	hPa	knots	mph	km/h
50	58	93	0.1198	4.06	4	4.6	7.4
60	69	111	0.1727	5.85	2	2.3	3.7
80	92	148	0.3075	10.41	2	2.3	3.7
100	115	185	0.4814	16.30	2	2.3	3.7
120	138	222	0.695	23.54	2	2.3	3.7
150	173	278	1.091	36.95	2.5	2.9	4.6

4. It is recommended to periodically send the unit to the manufacturer or authorized representative for an inspection every 5 years to perform pressure calibration if needed.
5. Check AFM is updated containing the Airplane flight manual supplement (AFMS) "Airplane Flight Manual supplement: Electronic Airspeed indicator + Altimeter ADI2"

8.1 Occurrence reporting

In case of issue with the ADI2, please contact **LXNAV d.o.o., Kidričeva ulica 24, SI-3000 Celje** via telephone **+386 592 33 40** or with an email **info@lxnav.com**.

9 Revision history

Rev	Date	Comments
01	October 2025	Initial release
02	March 2026	Editorial changes
03	March 2026	Correct labeling
04	April 2026	Updated ch 3.1.3
05	April 2026	Updated ch 7.4.3
06	April 2026	Updated ch. 7.3
07	April 2026	Updated ch. 5

The pilot's choice



LXNAV d.o.o.

Kidričeva 24, SI-3000 Celje, Slovenia

T: +386 592 334 00 | F:+386 599 335 22 | info@lxnav.com

www.lxnav.com